

NOTE

- 1. 端子テール部およびネイルの平坦度: 0.1mm MAX
TAIL AND NAIL COPLANARITY TO BE 0.1mm MAX
- 2. (極数/2) = 偶数 に適用
APPLY FOR (CIRCUIT SIZE/2) = EVEN.
- 3. 関連製品・書類はSHEET5を参照ください
REFER TO SHEET 5 ABOUT RELATED PRODUCTS AND DOCUMENTS.

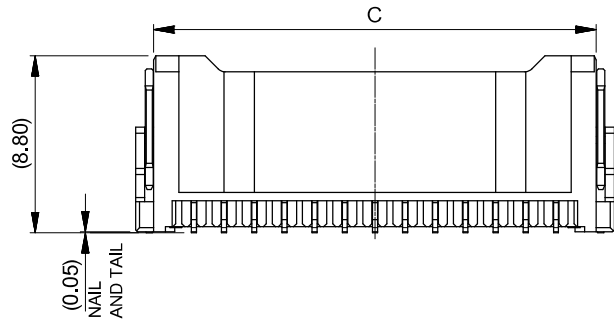
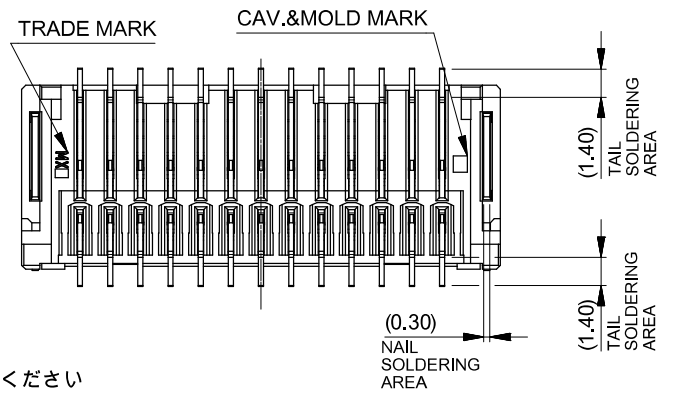
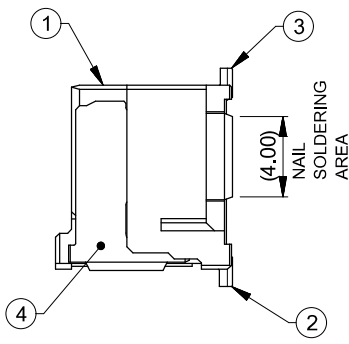
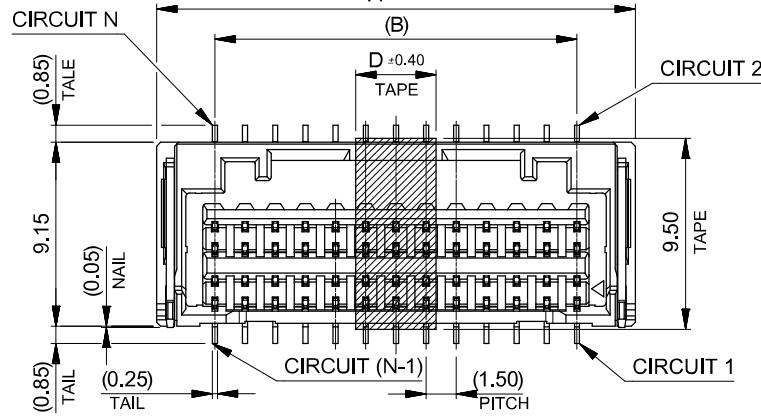
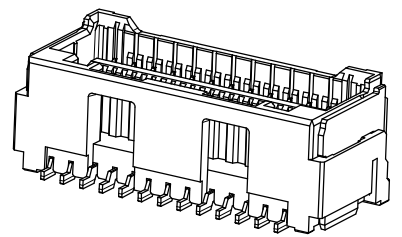

4. オーダー番号(製品番号): SHEET 6の製品一覧を参照ください
ORDER No. (PRODUCT No.): REFER TO SHEET 6 FOR PRODUCT LIST.

213227 * * * *

シリーズ番号 極数 色
SERIES NO CIRCUIT SIZE COLOR
金めっき厚
GOLD PLATING THICKNESS

CIRCUIT	No.	GOLD THK [micro-meter]	No.	COLOR
08 ~ 34	1	0.1	0	ナチュラル NATURAL
	3	0.38	1	黒 BLACK
	7	0.76		

D	C	B	A	極数		
				CKT NO		
5	28.0	±0.25	24.0	29.8	34	
	26.5		22.5	28.3	32	
	25.0		21.0	26.8	30	
	4		23.5	19.5	25.3	28
			22.0	18.0	23.8	26
			20.5	16.5	22.3	24
			19.0	15.0	20.8	22
3	17.5	13.5	19.3	20		
	16.0	12.0	17.8	18		
	14.5	10.5	16.3	16		
	13.0	9.0	14.8	14		
	11.5	7.5	13.3	12		
3	10.0	6.0	11.8	10		
	8.5	±0.2	4.5	10.3	8	

番号 NO	部品 PART	材質 MATERIAL
①	ハウジング HOUSING	ポリアミド(PA) UL94V-0 色: SEE CHART POLYAMIDE(PA) UL94V-0 COLOR: SEE CHART
②	ターミナル TERMINAL	銅合金 COPPER ALLOY
		コンタクト部 CONTACT AREA
③	テール部 TAIL AREA	金めっき: 製品一覧参照 GOLD PLATING: SEE PRODUCT LIST
		無光沢錫めっき: 1.0 micro-meter MIN MATTE TIN PLATING: 1.0 micro-meter MIN
④	ネイル NAIL	ニッケルめっき(全面) UNDER PLATING (WHOLE SURFACE)
		無光沢錫めっき: 1.0 micro-meter MIN MATTE TIN PLATING
		ニッケルめっき(下地): 1.0 micro-meter MIN NICKEL PLATING (UNDER PLATING)

THIS DRAWING CONTAINS INFORMATION THAT IS PROPRIETARY TO MOLEX ELECTRONIC TECHNOLOGIES, LLC AND SHOULD NOT BE USED WITHOUT WRITTEN PERMISSION

DIMENSION UNITS: mm SCALE: 4:1 GENERAL TOLERANCES (UNLESS SPECIFIED): ANGULAR TOL: ± 3.0° 4 PLACES: ± 0.2 3 PLACES: ± 0.2 2 PLACES: ± 0.2 1 PLACE: ± 0.2 0 PLACES: ± 0.2 DRAFT WHERE APPLICABLE MUST REMAIN WITHIN DIMENSIONS	CURRENT REV DESC: EC NO: 627908 DRWN: MIKEDA01 CHK'D: SAKIYAMA APPR: KOMURAKAMI INITIAL REVISION: DRWN: MIKEDA01 APPR: KOMURAKAMI THIRD ANGLE PROJECTION	2019/11/22 2019/11/22 2019/11/25 2019/10/01 2019/11/20 A3-SIZE 213227	CLIK-MATE 1.5 DUAL ROW SMT VT TYPE GOLD PLATING PRODUCT CUSTOMER DRAWING DOCUMENT NUMBER: 2132270000-SD DOC TYPE: PSD DOC PART: 000 REVISION: B MATERIAL NUMBER: 213227**** CUSTOMER: GENERAL SHEET NUMBER: 1 OF 6
--	--	---	---

CIRCUIT N
コネクタ外形
CONNECTOR OUTLINE

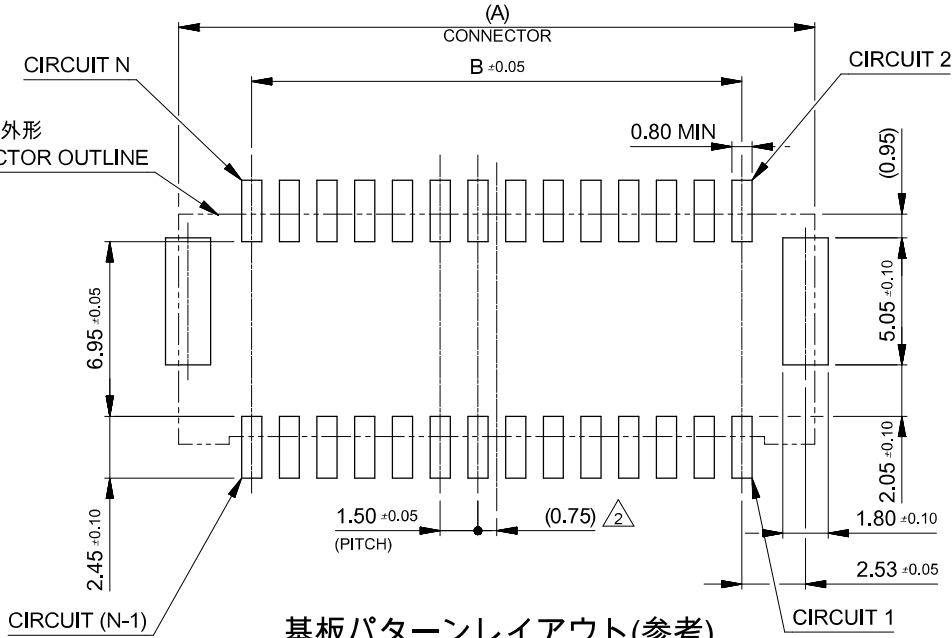

基板パターンレイアウト(参考)
RECOMMENDED PCB PATTERN LAYOUT (REF.)
(参考: メタルマスク厚さ 0.10mm, マスク開口率100%)
(REFERENCE: METAL MASK THICKNESS 0.10MM, APERTURE RATIO 100%)

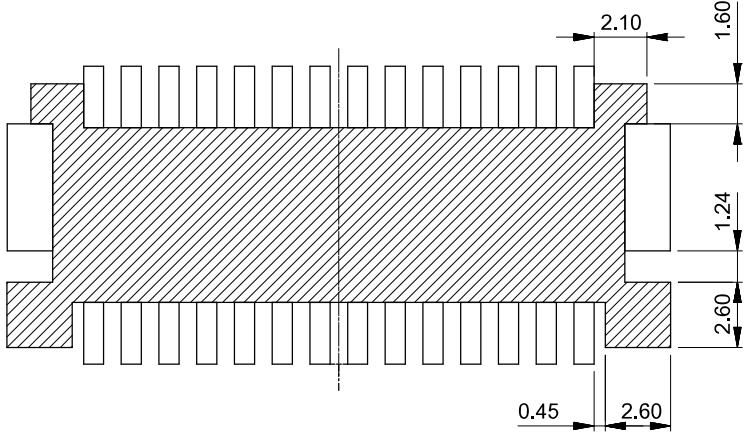

パターン非推奨エリア

パターンを引き回す際は、製品機能に影響がないことをご確認ください。
PATTERN IS NOT RECOMMENDED ON THE HATCHED AREA.
PLEASE CHECK NOT TO HAVE PROBLEM FOR PRODUCT FUNCTION
WHEN SETTING PATTERN ON THE HATCHED AREA.

THIS DRAWING CONTAINS INFORMATION THAT IS PROPRIETARY TO MOLEX ELECTRONIC TECHNOLOGIES, LLC AND SHOULD NOT BE USED WITHOUT WRITTEN PERMISSION		CURRENT REV DESC:		molex	
mm	SCALE 5:1				
GENERAL TOLERANCES (UNLESS SPECIFIED)		EC NO: 627908		CLICK-MATE 1.5	
ANGULAR TOL	± 3.0°	DRWN: MIKEDA01	2019/11/22	DUAL ROW SMT VT TYPE GOLD PLATING	
4 PLACES	± 0.2	CHK'D: SAKIYAMA	2019/11/22	PRODUCT CUSTOMER DRAWING	
3 PLACES	± 0.2	APPR: KOMURAKAMI	2019/11/25	DOCUMENT NUMBER	DOC TYPE DOC PART REVISION
2 PLACES	± 0.2	INITIAL REVISION:		2132270000-SD	PSD 000 B
1 PLACE	± 0.2	DRWN: MIKEDA01	2019/10/01	MATERIAL NUMBER CUSTOMER	
0 PLACES	± 0.2	APPR: KOMURAKAMI	2019/11/20	213227****	GENERAL
DRAFT WHERE APPLICABLE MUST REMAIN WITHIN DIMENSIONS		THIRD ANGLE PROJECTION	DRAWING A3-SIZE	SERIES 213227	SHEET NUMBER 2 OF 6

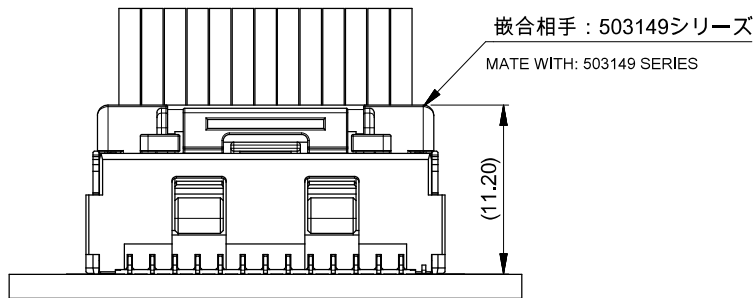
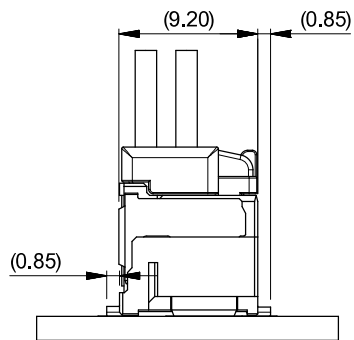

嵌合図
MATED CONNECTORS

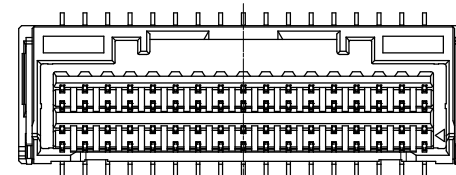
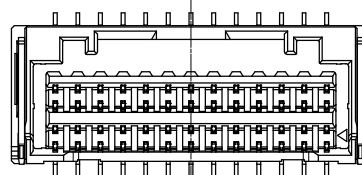
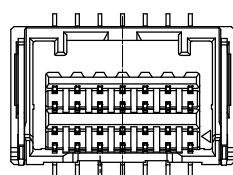
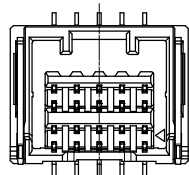
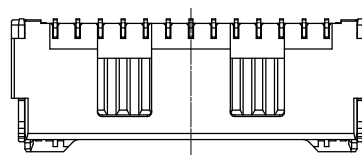
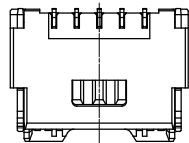

8-10極
8-10 CKT

12-18極
12-18 CKT

20-28極
20-28 CKT

30-34極
30-34 CKT

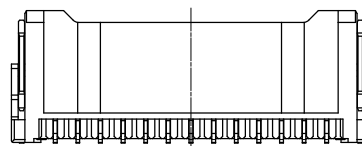
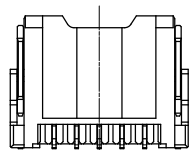

極数別ハウジング形状
HOUSING SHAPE OF EACH CKTS

THIS DRAWING CONTAINS INFORMATION THAT IS PROPRIETARY TO MOLEX ELECTRONIC TECHNOLOGIES, LLC AND SHOULD NOT BE USED WITHOUT WRITTEN PERMISSION		CURRENT REV DESC:			
DIMENSION UNITS: mm SCALE: 5:1 GENERAL TOLERANCES (UNLESS SPECIFIED): ANGULAR TOL: ± 3.0° 4 PLACES: ± 0.2 3 PLACES: ± 0.2 2 PLACES: ± 0.2 1 PLACE: ± 0.2 0 PLACES: ± 0.2 DRAFT WHERE APPLICABLE MUST REMAIN WITHIN DIMENSIONS	EC NO: 627908 DRWN: MIKEDA01 CHK'D: SAKIYAMA APPR: KOMURAKAMI	2019/11/22 2019/11/22 2019/11/25	PRODUCT CUSTOMER DRAWING DOCUMENT NUMBER: 2132270000-SD DOC TYPE: PSD DOC PART: 000 REVISION: B		
INITIAL REVISION: DRWN: MIKEDA01 APPR: KOMURAKAMI	2019/10/01 2019/11/20	MATERIAL NUMBER: 213227**** CUSTOMER: GENERAL	SHEET NUMBER: 3 OF 6		

適用製品及び各種仕様書
 APPLICABLE PRODUCTS AND VARIOUS SPECIFICATIONS

梱包仕様書 PACKAGING SPECIFICATION	PART NUMBER 213227 ****	DOCUMENT NUMBER 2132279200-SPK
----------------------------------	----------------------------	-----------------------------------

適用嵌合相手 MATE WITH	HOUSING	TERMINAL (GOLD PLATING)		
		PLATING THK	#24-28	#28-30
製品番号 PRODUCT NUMBER	503149 ****	0.1 micro-meters	213028 1*00	213029 1*00
		0.38 micro-meters	213028 3*00	213029 3*00
		0.76 micro-meters	213028 7*00	213029 7*00
製品仕様書 PRODUCT SPECIFICATION	5031490001-PS/PS/000			
アプリケーション仕様書 APPLICATION SPECIFICATION	AS-503149-001 (Japanese ver) 5031490000/PS/000 (English ver)			

THIS DRAWING CONTAINS INFORMATION THAT IS PROPRIETARY TO MOLEX ELECTRONIC TECHNOLOGIES, LLC AND SHOULD NOT BE USED WITHOUT WRITTEN PERMISSION									
DIMENSION UNITS	SCALE	CURRENT REV DESC:				molex			
mm	1:1								
GENERAL TOLERANCES (UNLESS SPECIFIED)		EC NO: 627908 DRWN: MIKEDA01 2019/11/22 CHK'D: SAKIYAMA 2019/11/22 APPR: KOMURAKAMI 2019/11/25 INITIAL REVISION: DRWN: MIKEDA01 2019/10/01 APPR: KOMURAKAMI 2019/11/20				CLIK-MATE 1.5 DUAL ROW SMT VT TYPE GOLD PLATING			
ANGULAR TOL	± 3.0°					PRODUCT CUSTOMER DRAWING			
4 PLACES	± 0.2					DOCUMENT NUMBER	DOC TYPE	DOC PART	REVISION
3 PLACES	± 0.2					2132270000-SD	PSD	000	B
2 PLACES	± 0.2					MATERIAL NUMBER	CUSTOMER	SHEET NUMBER	
1 PLACE	± 0.2					213227****	GENERAL	5 OF 6	
0 PLACES	± 0.2								
DRAFT WHERE APPLICABLE MUST REMAIN WITHIN DIMENSIONS	THIRD ANGLE PROJECTION	DRAWING	SERIES						
			A3-SIZE	213227					



DOCUMENT STATUS	P1	RELEASE DATE	2019/11/25 01:51:45
-----------------	----	--------------	---------------------

4 製品一覧
PRODUCTS LIST

黒 BLACK	ナチュラル NATURAL	HOUSING COLOR	
213227 3411	213227 3410	34	213227 **1* (GOLD PLATING THICKNESS: 0.1 micro-meters MIN)
213227 3211	213227 3210	32	
213227 3011	213227 3010	30	
213227 2811	213227 2810	28	
213227 2611	213227 2610	26	
213227 2411	213227 2410	24	
213227 2211	213227 2210	22	
213227 2011	213227 2010	20	
213227 1811	213227 1810	18	
213227 1611	213227 1610	16	
213227 1411	213227 1410	14	
213227 1211	213227 1210	12	
213227 1011	213227 1010	10	
213227 0811	213227 0810	8	
オーダー番号 ORDER No		極数 CKT	MODEL NO

黒 BLACK	ナチュラル NATURAL	HOUSING COLOR	
213227 3431	213227 3430	34	213227 **3* (GOLD PLATING THICKNESS: 0.38 micro-meters MIN)
213227 3231	213227 3230	32	
213227 3031	213227 3030	30	
213227 2831	213227 2830	28	
213227 2631	213227 2630	26	
213227 2431	213227 2430	24	
213227 2231	213227 2230	22	
213227 2031	213227 2030	20	
213227 1831	213227 1830	18	
213227 1631	213227 1630	16	
213227 1431	213227 1430	14	
213227 1231	213227 1230	12	
213227 1031	213227 1030	10	
213227 0831	213227 0830	8	
オーダー番号 ORDER No		極数 CKT	MODEL NO

黒 BLACK	ナチュラル NATURAL	HOUSING COLOR	
213227 3471	213227 3470	34	213227 **7* (GOLD PLATING THICKNESS: 0.76 micro-meters MIN.)
213227 3271	213227 3270	32	
213227 3071	213227 3070	30	
213227 2871	213227 2870	28	
213227 2671	213227 2670	26	
213227 2471	213227 2470	24	
213227 2271	213227 2270	22	
213227 2071	213227 2070	20	
213227 1871	213227 1870	18	
213227 1671	213227 1670	16	
213227 1471	213227 1470	14	
213227 1271	213227 1270	12	
213227 1071	213227 1070	10	
213227 0871	213227 0870	8	
オーダー番号 ORDER No		極数 CKT	MODEL NO

THIS DRAWING CONTAINS INFORMATION THAT IS PROPRIETARY TO MOLEX ELECTRONIC TECHNOLOGIES, LLC AND SHOULD NOT BE USED WITHOUT WRITTEN PERMISSION									
DIMENSION UNITS		SCALE		CURRENT REV DESC:					
mm		1:1							
GENERAL TOLERANCES (UNLESS SPECIFIED)									
ANGULAR TOL ± 3.0°				EC NO: 627908					
4 PLACES ± 0.2				DRWN: MIKEDA01		2019/11/22		CLICK-MATE 1.5	
3 PLACES ± 0.2				CHK'D: SAKIYAMA		2019/11/22		DUAL ROW SMT VT TYPE GOLD PLATING	
2 PLACES ± 0.2				APPR: KOMURAKAMI		2019/11/25		PRODUCT CUSTOMER DRAWING	
1 PLACE ± 0.2				INITIAL REVISION:				DOCUMENT NUMBER	
0 PLACES ± 0.2				DRWN: MIKEDA01		2019/10/01		2132270000-SD	
				APPR: KOMURAKAMI		2019/11/20		PSD 000 B	
DRAFT WHERE APPLICABLE MUST REMAIN WITHIN DIMENSIONS				THIRD ANGLE PROJECTION		DRAWING		SERIES	
						A3-SIZE		213227	
				MATERIAL NUMBER		CUSTOMER		SHEET NUMBER	
						GENERAL		6 OF 6	